



Specification Information

Product Code: 705-100

Product Name: Wall Mounted Liquid Soap Dispenser

Individual Carton UPC: 624622705008

Individual Carton Shipping Dimensions: 7.8cm W x 17.1cm H x 15.2cm D (3 1/8" W x 6 3/4" H x 6 1/2" D)

Individual Carton Shipping Weight: 0.68 kg (1.5 lbs)

Site Location: Frost's 705-100 manual wall mounted liquid soap dispenser is practical, economical, and durable. This unit has a bulk filled reservoir which allows the end user to save costs and buy soap in bulk from various suppliers instead of locking into a cartridge system. Typically, these products are used in schools, malls, restaurants, office buildings, recreational facilities, and other commercial properties. For locations requiring a cost efficient wall mounted liquid soap solution, this dispenser is an ideal choice.

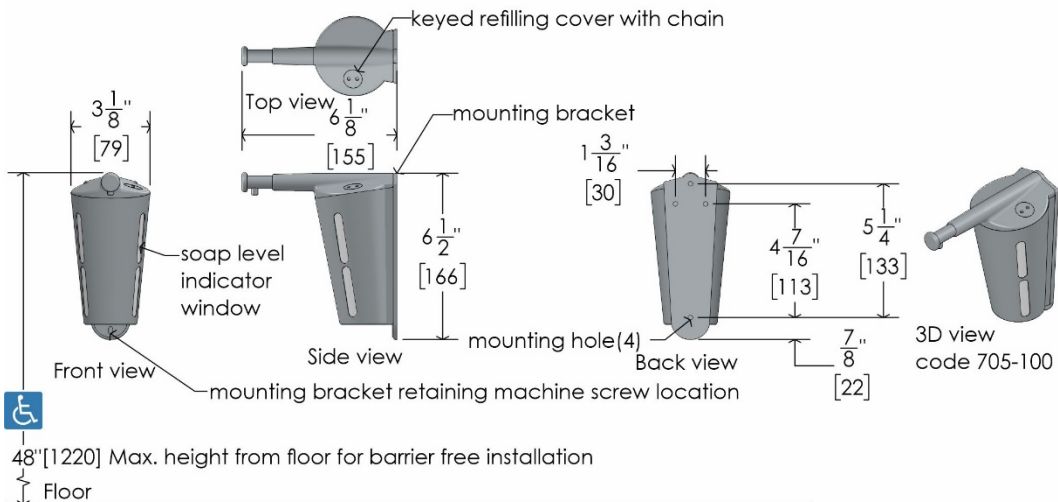

Features:

- Easy to operate and maintain
- Wall mounted with concealed mounting
- Soap level indicator slots
- Chained keyed filler cap
- Bulk filled
- For use with liquid soap
- Provides clean and professional appearance

Dispensing: Frost's 705-100 dispenses liquid soap manually by pressing the front spout inwards. This product is also universal; meaning, the unit is non-proprietary and dispenses soap from standard commercial soap suppliers. This allows the end user to avoid getting locked into soap supply contracts and should save them money on their janitorial supplies. To refill this product, use the key provided to open the top hatch, then pour liquid soap into the reservoir. The 705-100 is for use with coconut oil base soap at 10%-20% solution. We do not recommend any soap types that have an ammonium based surfactant, i.e. Ammonium Lauryl Sulfate.

Capacity:

- The bulk filled reservoir holds 0.35 litres (12 US oz.) of liquid soap

Materials:

- Main Housing and Spout: Steel, chrome plated

Frost Products Ltd

5276 John Lucas Drive
Burlington, ON, Canada, L7L5Z9

(905) 332-5700
1-800 667-5094

info@frostproductsltd.com
www.frostproductsltd.com



Specification Information

Product Dimensions:

- 7.9cm W x 16.5cm H x 15.5cm D (3.1" W x 6.5" H x 6.1" D)

Product Weight:

- 0.68 kg (1.5 lbs)

Installation Guidelines: Secure mounting plate to wall through holes with four mounting screws provided. Slip dispenser over mounting plate and secure with single machine screw at bottom.

Maintenance: Normal preventative maintenance and cleaning will keep Frost products functioning properly and may extend normal product life. Products should be wiped down with a damp soft cloth periodically. Approved stainless steel cleaner may be used to clean scuffs or fingerprints on stainless surfaces. Do not use harsh detergents or chemical cleaners. For general dirt and blemishes on painted steel or plastic use warm water and mild soap, or a general mild cleaning solution. When using any type of cleaning solution, spray onto a discrete area to test before full usage. After the cleaning agent is applied, wipe off with a clean soft cloth or sponge. It is recommended that units be periodically rinsed out with warm water to prevent soap build up that may hinder the performance of the valve. It is also recommended that users avoid harsh chemical cleaners when cleaning the outside of the unit.

Warranty: If any product or part proves to be defective within 12 months from date of shipment from the factory it will be repaired or replaced without any charge including freight costs when authorized. Costs resulting from the installation or removal of defective products are not covered under this warranty. Discolouration to stainless steel parts resulting from exposure to harsh environmental and / or chemicals are not considered to be defects in workmanship or material and are not covered under warranty.